

**FISCHBEIN PORTABLE  
BAG CLOSER  
SERIES ECR**

**OPERATING INSTRUCTIONS**

**FISCHBEIN COMPANY**

DIVISION OF AXIA INCORPORATED  
151 WALKER ROAD  
STATESVILLE, N.C. 28677, U.S.A.  
(704) 871-1159

# TABLE OF CONTENTS

TABLE OF CONTENTS .....	1
OPERATION .....	2
Procedure .....	2
Closing a bag .....	3
Recommendations .....	3
Threading .....	4
MAINTENANCE .....	5
Lubrication .....	5
Cleaning .....	5
Needle replacement .....	7
Looper replacement .....	7
Looper stroke adjustment .....	8
Needle bar adjustment .....	9
Looper clearance adjustment .....	9
Length adjustment .....	10
Feed dog height adjustment .....	10
Motor instructions .....	10
ILLUSTRATIONS .....	12
Housing, needle lever, presser foot .....	12
Main shaft & looper assembly .....	14
Handle & electric drive .....	16
Motor .....	18
OPTIONAL EQUIPMENT	
ECR-12V - 12VDC motor .....	23
ER - Air motor .....	25
EH - Handle and drive .....	27
ECR-1 - Tape attachment .....	29
Horizontal stitcher .....	30

## SUGGESTIONS

To insure successful operation of machine, study following instructions with care. Machine is shipped with sample of sewing. Check sample for stitching and chain appearance. After studying instructions, practice sewing on the sample or an empty bag until control of machine is mastered. Then proceed to close filled bags.

## SERVICE

Contact Fischbein Co. for the location of your authorized Fischbein representative for prompt service, thread, oil, and parts supplies.

## SAFETY INSTRUCTIONS

### PROPER OPERATING PROCEDURES

Hold machine in right hand with forefinger on switch button at bottom of handle. A slight finger pressure against switch button will start machine. Machine automatically stops when pressure is released.

Hold bag top in left hand at starting side and position the bag material close to and between machine's presser foot and throat plate. Machine will now automatically engage bag when starting button is pressed. After sewing an inch or two on bag, stop machine by releasing starting button. Then move left hand to finishing side of bag and proceed to finish closing.

To finish the closing operation, run machine off the bag two or three inches. With machine running, pull thread chain into "V" shaped slot at rear of throat plate where moving knife will automatically cut thread chain. With a little practice, thread cutting operation can be accomplished swiftly by merely rotating the machine slightly in a counter clockwise direction after the bag has been closed.

**Important! Always sew well above contents of bag. Do not sew farther than four inches down from the top of textile bag, and not more than two inches down from top of paper bag. Never interfere with the feeding of the machine as it sews across the bag, either by pulling it, holding it back, or pulling up.**

## HOW TO CLOSE A PAPER BAG

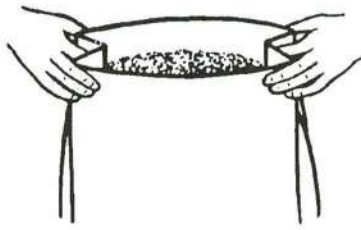

Figure No. 1

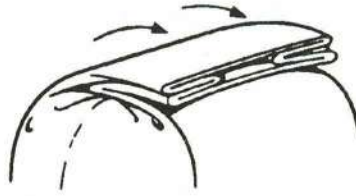

Figure No. 2

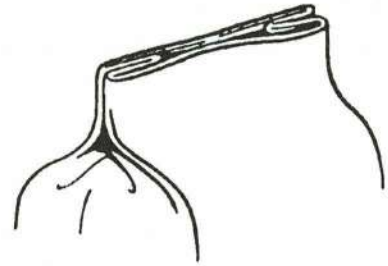

Figure No. 3

After bag is filled, weighed, and ready for closing, the operator should first reform gussets. see FIG. NO. 1. Next, fold or "break" top of bag sharply over contents. see FIG. NO. 2. Bring top of bag upright into closing position. The sides will be close together, smooth and wrinkle free. See FIG. NO. 3. Proceed with sewing operation, **but sewing no more than two inches down from top of bag.** If sifting is a problem, merely tuck in the inner ply tightly over contents and proceed to sew remaining plies. NOTE: Sufficient top is necessary to properly "break" bag.

When closing bags that are thick seamed on both sides such as Calcutta or Sisal bags, pull the seam on the starting side of bag two or three inches to one side, so that you start closing on the bag proper and not on the seam. See Fig. No. 4.

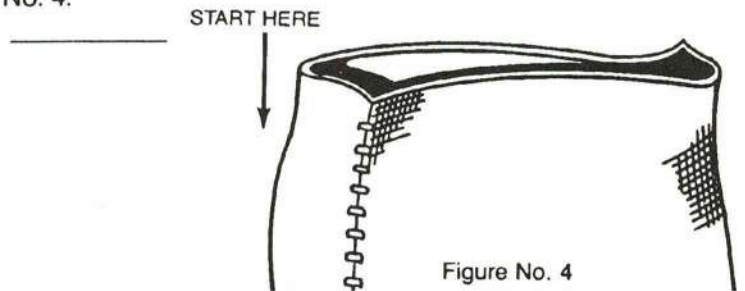

Figure No. 4

## GENERAL RECOMMENDATIONS

The machine uses a number 12, 4-ply thread, wound on 8-oz. cones For maximum strength be sure and use only Fischbein Premium Synthetic Thread. Each cone will close about 450 normal size 50 lb. bags. Installation of any kind is not necessary. Merely arrange a box, shelf or bracket so that, between bags operator can conveniently set machine down or suspend it from the ceiling with a Fischbein Model 1550 suspension unit.



Do not operate machine on voltages other than specified for the machine. Machine feeds automatically. Don't pull or hold it back as it feeds across the bag. Don't try to operate machine with bent or blunt needle. Don't disturb connecting rod and eccentric, part No. 11079, or looper cam, part No. 11310. They are timed and set. at factory.

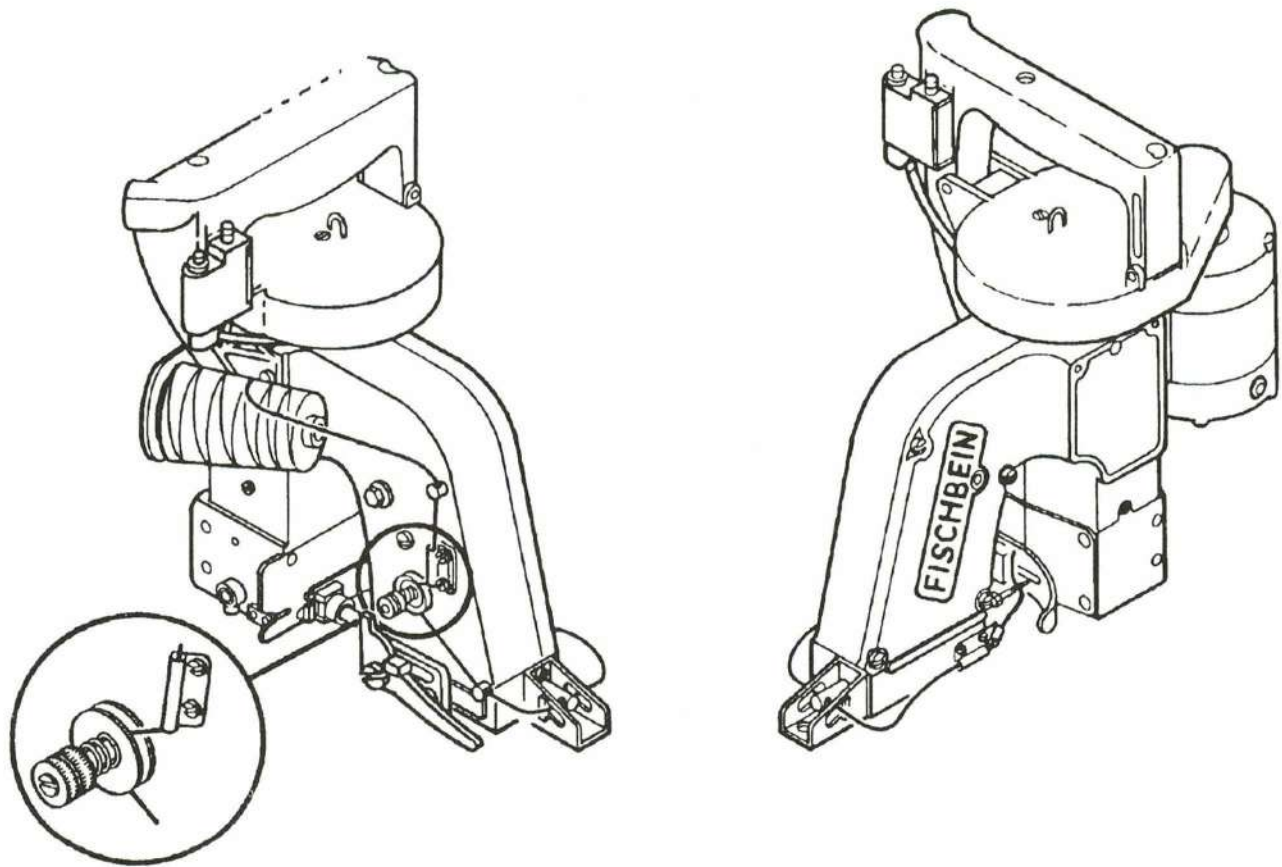

### THREADING AND TENSION

To install new cone of thread, push thread clamping bolt, part No. 11804, through hole in top of cone and securely lock in position with wing nut, part No. 11805. Cone of thread must not rotate or wobble on thread stand. Follow illustration above, being sure that thread passes between the two tension discs, parts No. 11114. Thread needle from outside to inside of machine. Leave about 1 1/2" of thread dangling through needle, and proceed to sew bags in normal manner.

**If asphalt laminated or water proof bags are being used, it is necessary to lubricate thread by soaking full cones in container of Fischbein Thread Lubricant.**

Tension is the degree of resistance the thread meets in passing between the tension discs, part No. 11114. Too loose a tension will cause the thread to tear or will leave loose loops of thread on the bag instead of nice firm stitches. Too tight a tension will also cause the thread to tear or will cause textile bag material to pucker. In either case, the machine may not chain off. To alter the amount of tension, loosen upper tension nut, part No. 11116. Turn lower tension nut, part No. 11117, about 1/8 turn at a time - up to loosen tension, or down to tighten tension - testing on material - until desired stitch appearance is obtained. Be sure to re-lock upper tension nut.

# FISCHBEIN SEWING HEAD

## SERIES ECR

### MAINTENANCE INSTRUCTIONS AND ADJUSTMENTS

**WARNING**

**ALWAYS UNPLUG THE MACHINE BEFORE DOING MAINTENANCE, PARTS REPLACEMENT OR ADJUSTMENTS.**

#### MAINTENANCE

##### NOTE:

Genuine Fischbein Cleaning Lubricant and #5-100 Lubricating Oil are available from any Authorized Representative.

##### Oiling (Figure 1):

This machine is equipped with a MANUAL OILING SYSTEM. The OIL RESERVOIR and the OIL PUMP are found at the cord-end of the HANDLE.

Oil Reservoir: Use Fischbein #5-100 Lubricating Oil. The OIL RESERVOIR and PUMP must have a supply of clean oil at all times.

The oil level can be viewed through the clear end of the reservoir.

##### CAUTION:

**Never operate this machine with the oil reservoir cap removed.**

To lubricate the moving parts: Press the BUTTON on the OIL PUMP two times.

This will dispense the correct amount of oil for an average four hours use under normal conditions.

##### Cleaning (Figure 2):

To clean the dirt from the machine:

1. Unthread the machine.
2. With the machine running, dip the portion shown in about four inches (100mm) of lubricant for about 10 seconds.
3. Use a brush to clean the back of the machine.

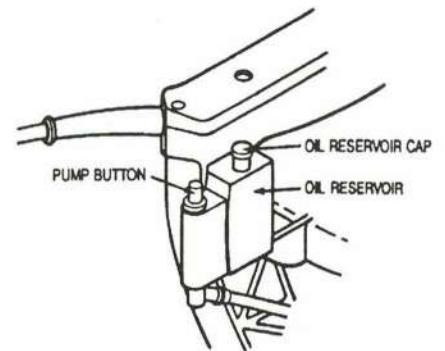

(FIGURE 1)

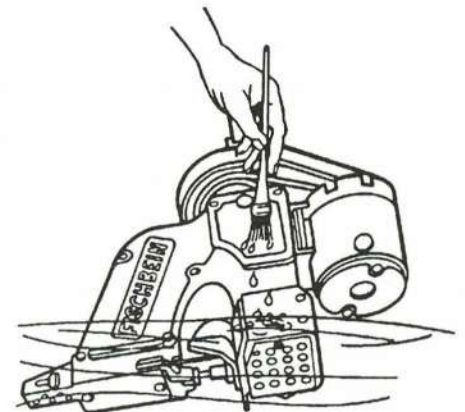

(FIGURE 2)

**WARNING**

**Use Fischbein Cleaning Lubricant.  
Do NOT use gasoline or similar agents.**

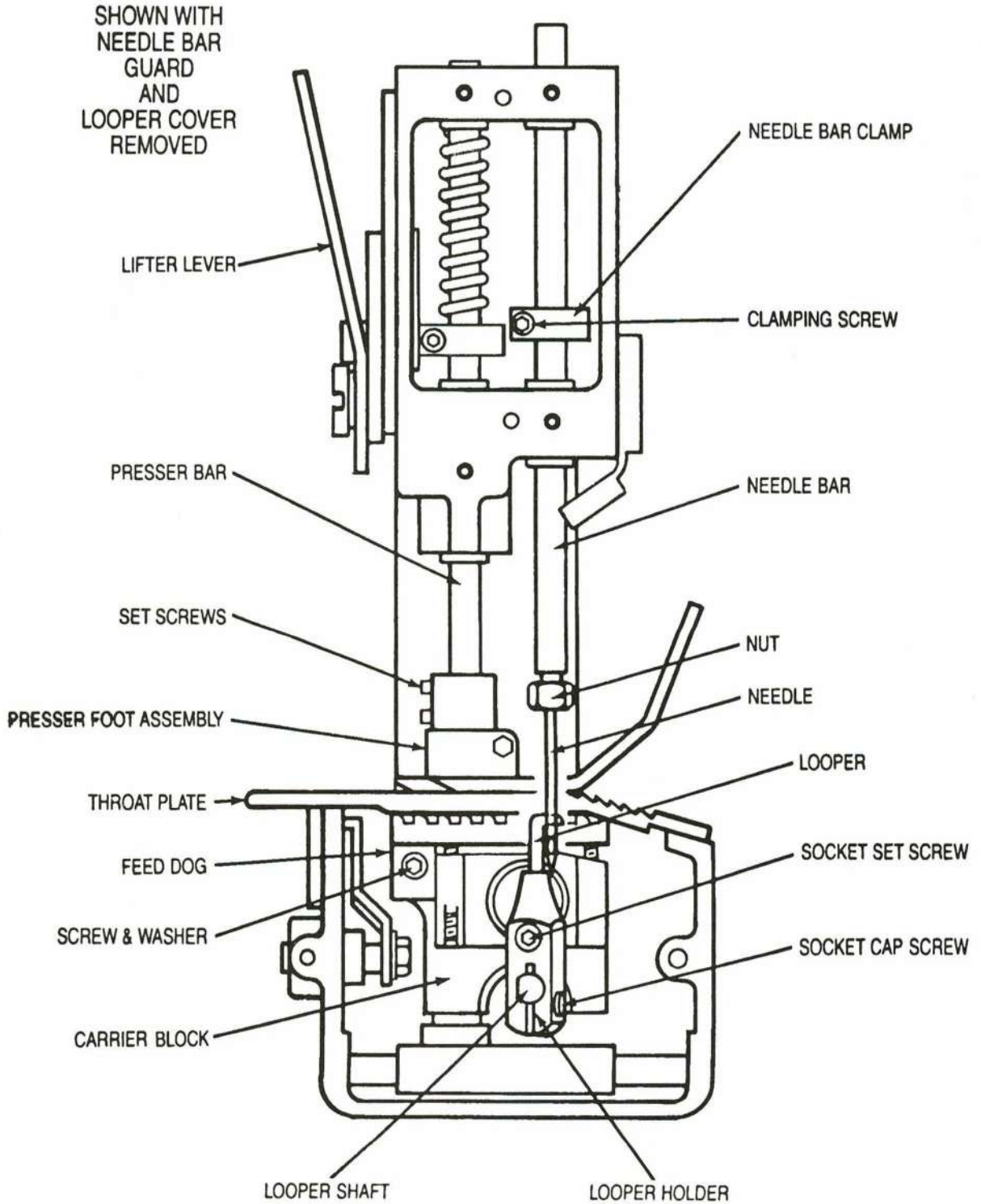

(FIGURE 3)

## REPLACING PARTS

Put the machine on a flat surface with the LOOPER COVER and the NEEDLE BAR GUARD facing you. Tip the machine back away from you until it rests on the HANDLE and the MOTOR. All replacements and adjustments described below are easier to perform with the machine in this position.

### To Replace the Needle

#### CAUTION:

When loosening or tightening the NEEDLE BAR NUT it is best to use the WRENCH provided. A heavier wrench may apply too much force, which will strip the threads or crack the nut.

1. Loosen the NEEDLE BAR NUT #11501 (Figure 5) using the WRENCH provided with the machine.
2. Turn the MACHINE PULLEY #11904 (Figure 4) until the needle is at its highest point.
3. Remove the NEEDLE by pulling it down and away from the nut.
4. Insert the new NEEDLE into the NEEDLE BAR as far as it will go. **The long groove in the needle must face toward the LOOPER COVER.** (Figure 5).
5. Tighten the NEEDLE BAR NUT firmly, using the WRENCH provided with the machine.

### To replace the Looper

1. Rotate the LIFTER LEVER until it locks into place as shown (Figure 6). This will raise the PRESSER FOOT above the THROAT PLATE.
2. Remove the NEEDLE. (Figure 5).
3. Remove the LOOPER COVER #11102. (One SCREW).
4. Remove the THROAT PLATE #11210. (Three SCREWS #F64038) (Figure 7).
5. Remove the FEED DOG #11203 (Figure 3):
  - a. Turn the machine PULLEY #11904 (Figure 4) until the FEED DOG is at its lowest position.
  - b. Remove the SCREW #SC8321 and the WASHER #WF8S.
  - c. Pull the FEED DOG gently off the CARRIER BLOCK #11437.
6. Install the new LOOPER.
  - a. Using an allen wrench, loosen the SET SCREW in LOOPER HOLDER #11301.
  - b. Pull out the old LOOPER #11300.
  - c. Insert the new LOOPER in the LOOPER HOLDER with the flat on the LOOPER SHANK facing the SET SCREW. Be sure that the new LOOPER is pushed as far as it will go into the LOOPER HOLDER.
  - d. Tighten the SET SCREW against the flat on the LOOPER SHANK.
7. Install a new needle and proceed with LOOPER and NEEDLE Bar adjustments.

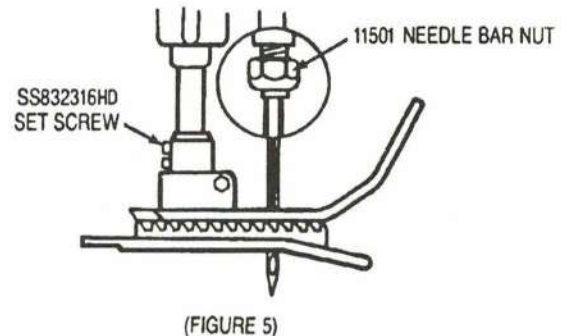
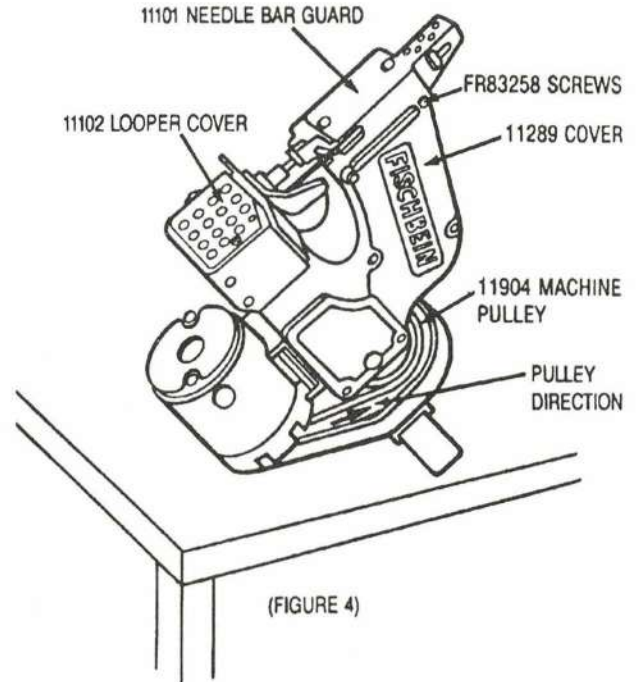



## Machine Adjustments

When adjusting machine always insert new NEEDLE. See section on NEEDLE REPLACEMENT.

### Looper Stroke Adjustment

1. Rotate the LIFTER LEVER out until it locks into place as shown (Figure 6). This will raise the PRESSER FOOT above the THROAT PLATE.

2. Remove the LOOPER COVER #11102. (One SCREW). (Figure 7).

3. Remove the THROAT PLATE #11210. (Three SCREWS #F64038). (Figure 7).

4. Remove the FEED DOG gently off the CARRIER BLOCK #11437.

5. Turn machine PULLEY #11904 until the LOOPER #11300 is at maximum back stroke position to left of NEEDLE.

The LOOPER stroke is correct when there is  $1/32"$  (.032") (.8mm) between LOOPER point and edge of NEEDLE when LOOPER is at maximum back stroke (Figure 8).

Use  $1/32"$  gauge (#11302) for checking this clearance. If correct proceed to next adjustment.

If incorrect remove housing cover #11289 (Figure 4).

Loosen socket cap screw #SC54058 (#11307) and rotate LOOPER unit  $1/32"$  (.032") (.8mm) until clearance is achieved. Reinstall cover.

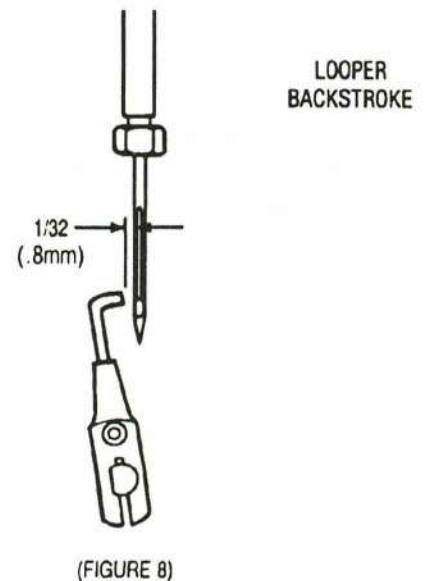
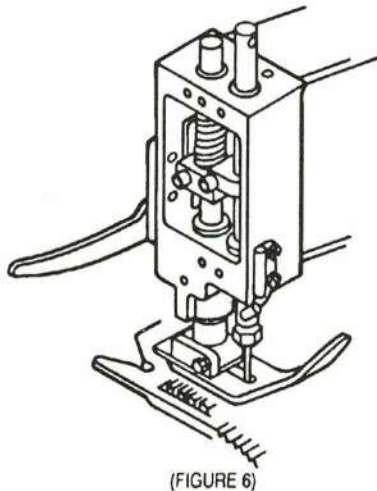
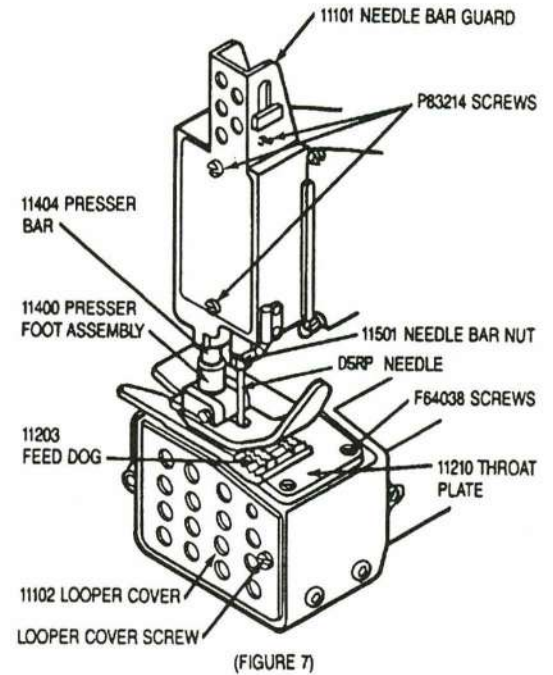

### Adjusting the Needle Bar height for Looper clearance

1. Remove the NEEDLE BAR GUARD (11101). (Three P83214 NEEDLE BAR GUARD SCREWS - One on the top of the guard - Figure 7).
2. Remove the LOOPER COVER #11102. (One LOOPER COVER SCREW - Figure 7).
3. Turn machine pulley #11904 until tip of LOOPER crosses and is flush with the side of the NEEDLE, or not more than 1/64" beyond.
4. Loosen slightly the CLAMPING SCREW on the NEEDLE BAR CLAMP #11502 (Figure 3).
5. Raise or lower the NEEDLE BAR as necessary until the bottom of the LOOPER #11300 is even with the top of the NEEDLE hole (Figure 9). **Do not change the LOOPER setting.**
6. Tighten the CLAMPING SCREW #SC54012 on the NEEDLE BAR CLAMP #11502 (Figure 3).
7. Check for proper clearance between the NEEDLE and the LOOPER as seen in Figure 10. The LOOPER clearance may be adjusted at this point, if necessary (see "Looper clearance Adjustment" as follows:)

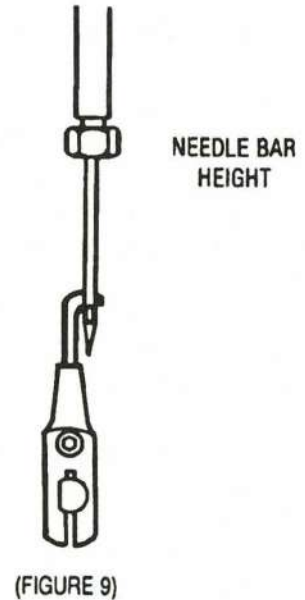

### Looper Clearance Adjustment

The point of the LOOPER must pass the NEEDLE SCARF as closely as possible. The NEEDLE SCARF is the hollowed out section of the NEEDLE on the ungrooved side just above the hole. (Figure 10).

If adjustment is necessary:

1. Loosen the LOOPER HOLDER SOCKET CAP SCREW (Figure 3).
2. Move the LOOPER HOLDER (#11301) (Figure 3) on the LOOPER SHAFT #11303 until the LOOPER is positioned as close as possible to the NEEDLE without touching the NEEDLE.
3. Tighten the LOOPER HOLDER SOCKET CAP SCREW.
4. Install FEED DOG, LOOPER COVER, and THROAT PLATE.

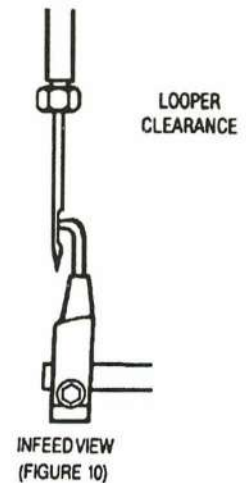

### Length Adjustment

The stitch length is set at the factory to give 3.5 stitches per inch (stitch length = 7.25mm). If the stitches shorten check the following:

If the teeth on the FEED DOG are worn, the stitches will be too short and the FEED DOG must be replaced.

The stitch length is controlled by the FEED DOG #11203 (Figure 11) which moves above and below the THROAT PLATE #11210

during the normal sewing cycle. At its highest point the top of the FEED DOG TEETH should be  $\frac{3}{32}$  of an inch (2.4mm) above the THROAT PLATE.

### Feed Dog Height Adjustment

If teeth on the FEED DOG are worn, the FEED DOG must then be replaced.

Feed dog height is controlled by adjustable set screws #SS64038HD in part #11437. These set screws should be adjusted so that at its highest point, the top of the FEED DOG is  $\frac{3}{32}$ "

(2.4mm) above the THROAT PLATE. For optimum performance the trailing edge of FEED DOG should be about .010" higher than leading edge.

Note: THERE is a set of locking screws #SS64038HD on underside of FEED CARRIER BLOCK (#11437). These must be locked into place.

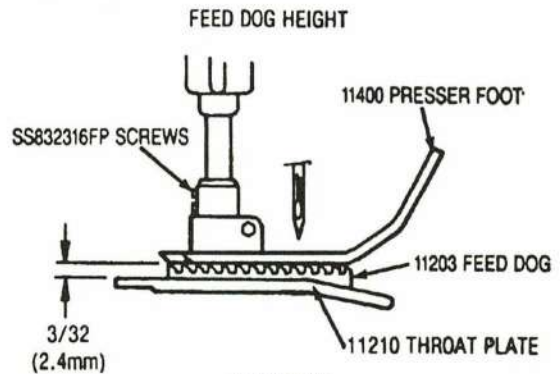

(FIGURE 11)

## MOTOR INSTRUCTIONS

This motor is intermittent duty, which means that it should not run for long periods of time continuously. It is made for start and stop operations only, such as required by bag closing.

**Brushes should be inspected at regular intervals so that wear can be detected and replaced before they are about  $\frac{1}{8}$ " in length.** To remove brushes, take out two screws from each side of motor. When replacing brush, be sure it is replaced at the same axial position as removed. If it isn't, excessive sparking and loss of power will result.

**FISCHBEIN SEWING HEAD**  
**SERIES ECR**

**PARTS ILLUSTRATION**

PLATE A

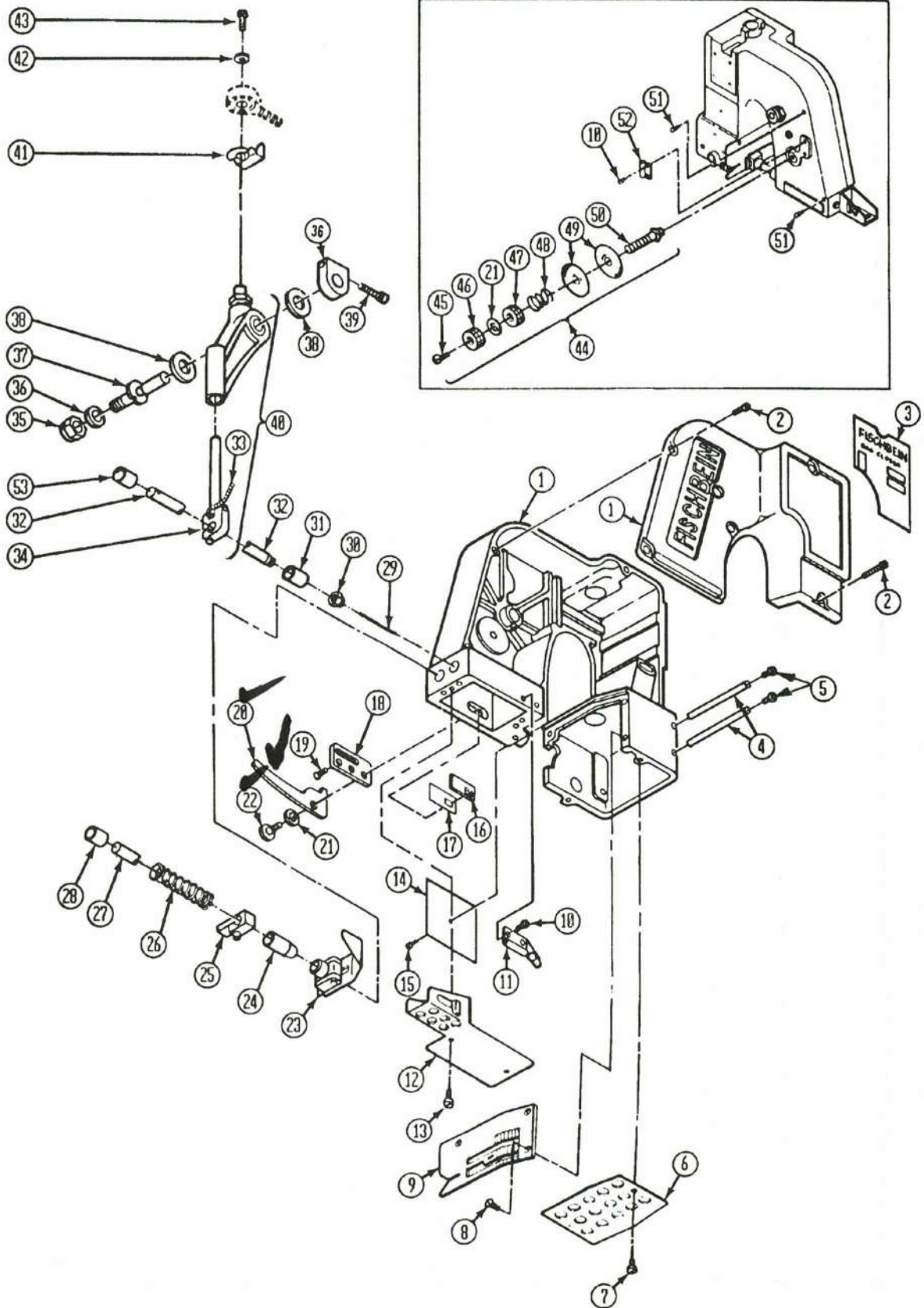

# MOD. ECR HOUSING, NEEDLE LEVER, PRESSER FOOT

ILLUSTRATED PARTS BREAKDOWN ORDER BY NUMBER

PLATE A

ITEM	QUAN.	PART NO.	DESCRIPTION
1	1	11448	ASSY.,HOUSING & COVER W/BUSHINGS
	5	SS832316	SCREW,SOC.SET #8-32N.C.X3/16 (SCREW FOR ALL BUSHINGS)
2	6	FR83258	SCREW,FILLISTER HD. - 8-32,N.C.X5/8
3	1	11004	NAMEPLATE
4	2	11010	STUD,FEED DOG,CARRIER SLIDE
5	4	SB103214	SCREW,SOC.BUTTON HD. - #10-32N.F.X1/4
6	1	11102	COVER,LOOPER
7	1	11108	SCREW,COVER - LOOPER
8	3	F84038	SCREW,FLAT HD. - #6/40N.F.X3/8
9	1	11210	PLATE,THROAT - STANDARD
	1	11212	PLATE,THROAT - TAPING
10	4	B632316	SCREW,BINDING HD.- #6/32N.C.X3/16
11	1	11321	TUBE,THREAD GUIDE(FRONT)
12	1	11101	GUARD,NEEDLE BAR
13	3	F83214	SCREW,PAN HD. - #8-32N.C.X1/4
14	1	11009	PLATE,COVER
15	1	B103214	SCREW,BINDING HD. - #10-32N.F.X.1/4
16	1	11657	COVER,SLIDE PAD
17	1	11656	PAD,SLIDE
18	1	11651	PLATE,LEVER
19	2	F832516	SCREW,FLATHEAD - #8-32N.C.X5/16
20	1	11654	LEVER,LIFTER - PRESSER FOOT
21	2	11655	WASHER,SPRING
22	1	11653	SCREW,PIVOT
23	1	11400	ASSY.,PRESSER FOOT - STANDARD
	1	11399	PRESSER FOOT,TAPING & PLASTIC
	1	11883	GUIDE, NEEDLE - PRESSER FOOT
	1	11402	BOLT,HINGING
	1	11711	NUT
	2	SS832316HD	SCREW,SOC.SET - #8-32N.C.X3/16 (FLAT POINT)
24	1	11444	BUSHING,PRESSER BAR - LOWER
25	1	11652	LIFTER,PRESSER FOOT
		SC64058	SCREW,SOCKET CAP - #6-40N.F.X5/8
26	1	11414	SPRING,PRESSER BAR
27	1	11404	PRESSER BAR
28	1	11442	BUSHING,NEEDLE BAR & PRESSER BAR - UPPER
29	1	D5	NEEDLE
30	1	11501	NUT,NEEDLE BAR
31	1	11719	BUSHING,NEEDLE BAR - LOWER
32	1	11500	NEEDLE BAR
33	1	11508	WICKING
34	1	11502	ASSY.,CLAMP - NEEDLE BAR
35	1	11268	NUT,LOCK(NYLOK SPECIAL)-3/8-24N.C.
36	1	A3934	WASHER,FLAT
37	1	11287	PIN,PIVOT
38	2	WT38132	WASHER,THRUST - NEEDLE LEVER
39	1	11008	CLAMP,PIVOT - NEEDLE
	1	SC64058	SCREW,SOC,CAP-#6-40N.F.X5/8
40	1	11099	ASSY.,CLAMP NEEDLE BAR LEVER
41	1	11510	SPRING
42	1	WF10	WASHER,FLAT - #10
43	1	H103212	SCREW,HEX HD. - #10-32N.F.X1/2
44	1	11112	ASSY.,TENSION - COMPLETE
45	1	F84038	SCREW,FLAT HD. - #6-40N.F.X3/8 (PART OF ITEM #44)
46	1	11118	NUT,TENSION - UPPER (PART OF ITEM #44)
47	1	11117	NUT,TENSION - LOWER (PART OF ITEM #44)
48	1	11115	SPRING,TENSION (PART OF ITEM #44)
49	2	11114	DISC,TENSION (PART OF ITEM #44)
50	1	11113	STUD,TENSION (PART OF ITEM #44)
51	2	11109	EYELET,THREAD PULLOFF
52	1	11118	TUBE,THREAD GUIDE - REAR
53	1	11718	BUSHING,NEEDLE BAR - UPPER
54	1	WL10	WASHER, LOCK #10

PLATE B

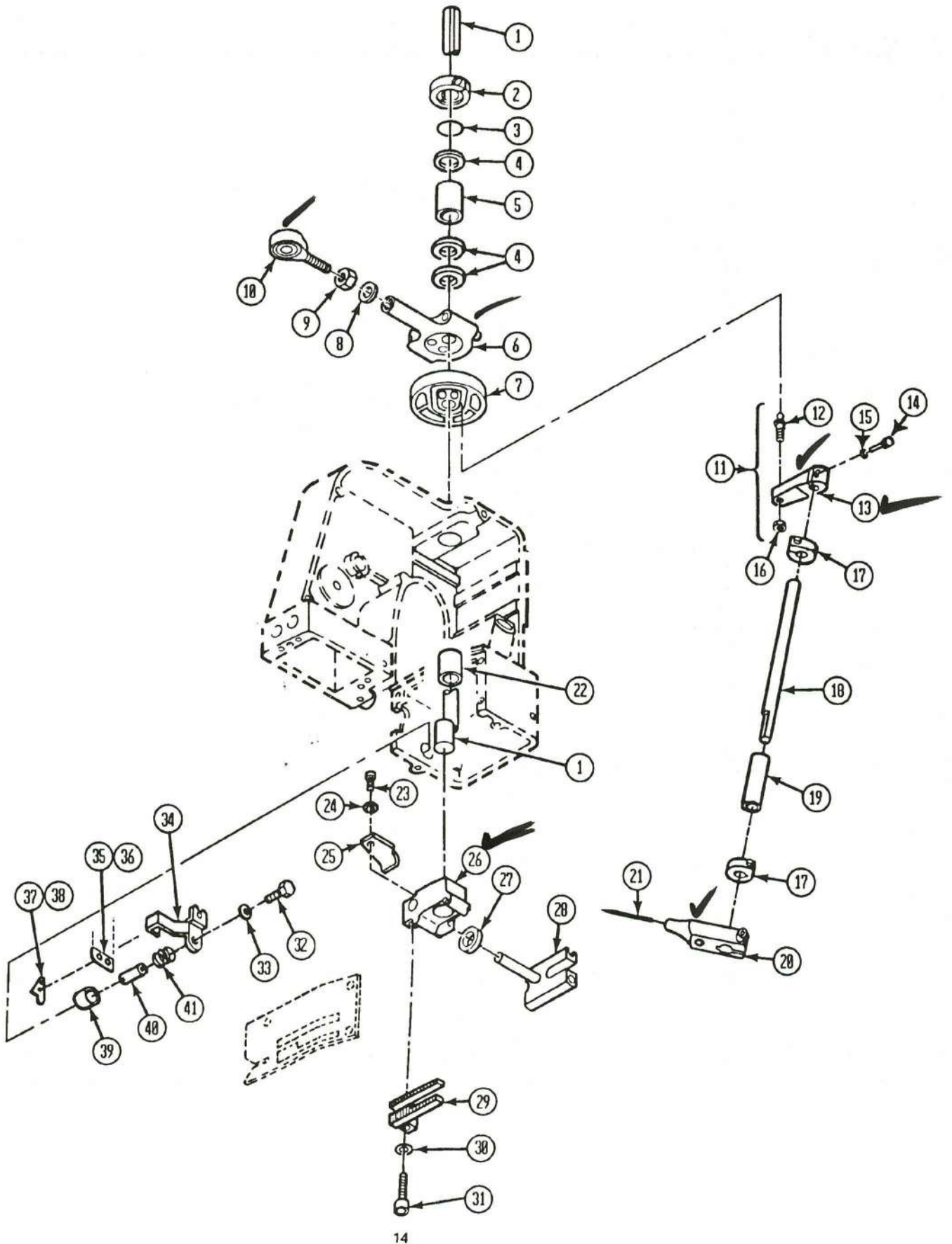

# MODEL ECR MAIN SHAFT & LOOPER ASSEMBLY

ILLUSTRATED PARTS BREAKDOWN ORDER BY NUMBER

PLATE B

ITEM	QUAN.	PART NO.	DESCRIPTION
1	1	11600	MAIN SHAFT
2	1	11616	COLLAR, MAIN SHAFT
	1	SC54038	SCREW, SOC. CAP - #5/40N.C.X3/8
3	1	10420	RING, "O"
4	3	11006	WASHER, THRUST
5	1	11441	BUSHING, MAIN SHAFT - REAR
6	1	11079	ASSY., CON ROD & ECCENTRIC
7	1	11310	ASSY., CAM - LOOPER
	1	SS103258CP	SCREW, SOC. SET - #10-32N.F.X5/8 (CONE POINT)
	1	SS103212	SCREW, SOC. SET - #10-32N.F.X1/2
8	1	WIT516	WASHER, INTERNAL TOOTH - 5/16
9	1	11608	NUT, HEX - SPECIAL
10	1	11607	BEARING, ROD END
11	1	11317	ASSY., ARM & STUD - CAM FOLLOWER
12	1	11308	STUD, CAM FOLLOWER (PART OF ITEM #11)
13	1	11307	ARM, FOLLOWER - CAM (PART OF ITEM #11)
14	1	SC54058	SCREW, SOC. CAP. - #5-40N.C.X5/8 (PART OF ITEM #11)
15	1	11313	WASHER, FLAT - #5(SPECIAL) (PART OF ITEM #11)
16	1	11309	NUT, HEX - SPECIAL (PART OF ITEM #11)
17	2	11304	COLLAR, LOOPER SHAFT
	2	SC54012	SCREW, SOC. CAP - #5-40N.C.X1/2
18	1	11303	SHAFT, LOOPER
19	2	11445	BUSHING, LOOPER SHAFT
20	1	11301	HOLDER, LOOPER
	1	SS832316HD	SCREW, SOC. SET - #8-32N.C.X3/16(HD)
	1	SC54038	SCREW, SOC. CAP - #5-40N.C.X3/8
21	1	11300	LOOPER
22	1	11447	BUSHING, MAIN SHAFT - FRONT
23	1	SB83238	SCREW, HEX HD. - #8-32N.C.X3/8
24	1	WIT8	WASHER, INTERNAL TOOTH - #8
25	1	11003	CLIP, ANGLE
26	1	11437	CARRIER BLOCK, FEED DOG
	4	SS64038HD	SCREW, SOC. SET - #6-40N.F.X3/8(HD)
27	1	11410	WASHER, FELT
28	1	11446	SLIDE
29	1	11203	FEED DOG
	1	11215	FEED DOG, SPECIAL(LINEN MACHINE ONLY)
30	1	WS8	WASHER, SPRING - #8
31	1	SC8321	SCREW, SOC. CAP - #8-32N.C.X1
32	1	H103238	SCREW, HEX HD. - #10-32N.F.X3/8
33	1	WIT10	WASHER, LOCK - #10
34	1	11007	BRACKET, KNIFE
35	1	11703	KNIFE, STATIONARY
36	2	F348316	SCREW, FLAT HD. - #3-48N.C.X3/16
37	1	11702	KNIFE, MOVING
38	2	F348316	SCREW, FLAT HD. - #3-48N.C.X3/16
39	1	11016	BUSHING, KNIFE SHAFT
40	1	11707	SHAFT, KNIFE
41	1	11704	SPRING, KNIFE - TENSION



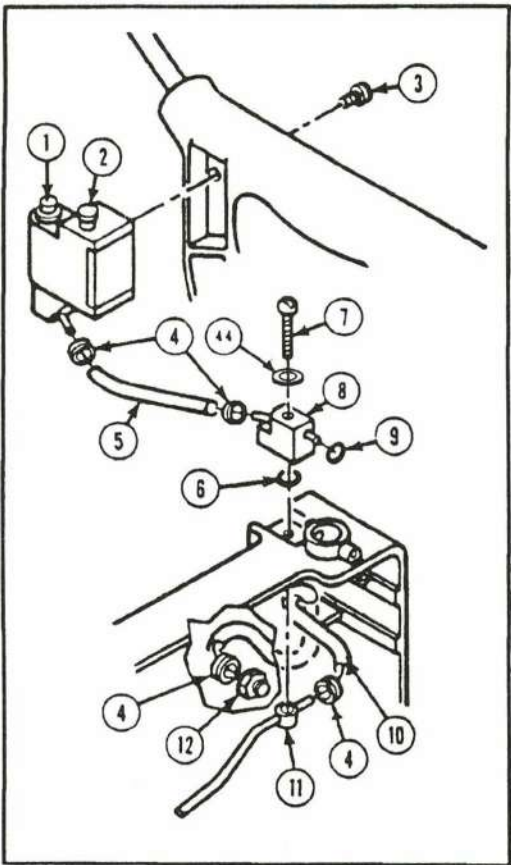
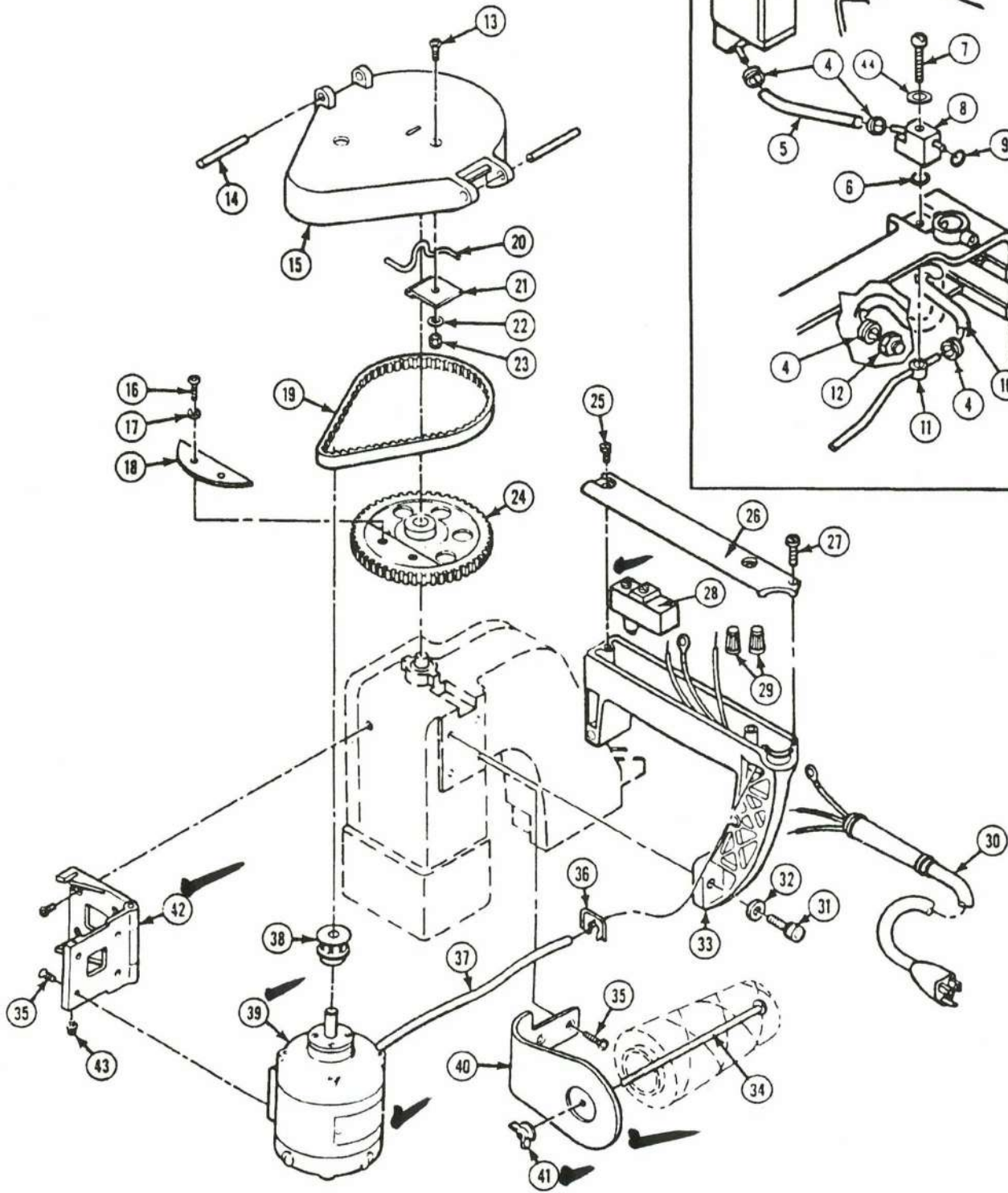

## MODEL ECR-1 HANDLE & ELECTRIC DRIVE

ITEM	QUAN.	PART NO.	DESCRIPTION
1	1	11450	ASSY.,PUMP - OIL
2	1	11453	CAP.OIL RESERVOIR
3	1	B83212	SCREW,BINDING HD. - #8-32N.C.X1/2
4	4	11472	CLAMP,GARTER - SPRING
5	1	11141	TUBING,OIL PUMP - PLASTIC
6	1	11479	RING,"O"
7	1	B832114	SCREW BINDING HD. - #8-32N.C.X1 1/4
8	1	11475	MANIFOLD,OUTSIDE
9	1	11478	RING,"O"
10	1	11489	TUBING,PLASTIC
11	1	11485	WELDMENT,MANIFOLD - INSIDE
12	1	11490	FITTING,BARBED
13	1	F832516	SCREW,FLAT HD. - #8-32N.C.X5/16
14	2	PS14112	PIN,SPRING - 1/4DIA.X1 1/2
15	1	11018	GUARD,BELT-SEE ASSEMBLIES AVAILABLE
16	2	SB83238	SCREW,SOC.BUTTON HD. - #8-32N.C.X3/8
17	2	WS8	WASHER,SPRING - #8
18	1	11938	COUNTERWEIGHT
19	1	11909	BELT
20	1	11012	HANGER
21	1	11017	CLIP,HANGER
22	1	WIT8	WASHER,INTERNAL TOOTH - #8
23	1	NH832	NUT,HEX - #8-32N.C.
24	1	11904	PULLEY
25	2	R103238	SCREW,ROUND HD. - #10-32N.F.X3/8
26	1	11011	COVER,HANDLE
27	1	FR44034	SCREW,FILLISTER HD. - #4-40N.C.X3/4
28	1	11819	SWITCH
29	2	76000	WIRE NUT
30	1	11808	CORD,SET
	1	11777	CORD,SET - 12V(10FT.)
31	2	SC142034	SCREW,SOC.CAP - 1/4-20N.C.X3/4
32	2	WS14	WASHER,SPRING - 1/4
33	1	11028	HANDLE-SEE ASSEMBLIES AVAILABLE
34	1	11804	BOLT,THREAD - CLAMPING
35	10	SF103238	SCREW,SOC.FLAT HD. - #10-32N.F.X3/8
36	1	11073	STRAIN RELIEF
37	1	12470	MOTOR LEAD - 3 WIRE SJO
38	1	11902	PULLEY MOTOR
39	1	11997	MOTOR,115V
	1	12451	MOTOR,230V
	1	12475	MOTOR,12V
40	1	11720	STAND,THREAD
41	1	11805	NUT,WING - 1/4-20N.C.
42	1	11906	ASSY.,HINGE MOTOR MOUNT
43	2	11908	SCREW,SEMS-PAN HD. - #6-32N.C.X7/16
44	1	WN8	WASHER, NYLON - #8

## ASSEMBLIES AVAILABLE

ITEM	QUAN.	PART NO.	DESCRIPTION
REF	REF	11198	ASSY.,GUARD - BELT
15	1	11018	GUARD,BELT
13	1	F832516	SCREW,FLAT HD. - #8-32N.C.X5/16
20	1	11012	HANGER
21	1	11017	CLIP,HANGER
22	1	WIT8	WASHER,INTERNAL TOOTH - #8
23	1	NH832	NUT,HEX - #8-32N.C.
15	1	11018	GUARD, BELT
REF	REF	11084	ASSY.,BELT GUARD & HANDLE
13	1	F832516	SCREW,FLAT HD. - #8-32N.C.X5/16
14	2	PS14112	PIN,SPRING - 1/4DIA.X1 1/2)
20	1	11012	HANGER
21	1	11017	CLIP,HANGER
22	1	WIT8	WASHER,INTERNAL TOOTH - #8
23	1	NH832	NUT,HEX - #8-32N.C.
33	1	11028	HANDLE
25	2	R103238	SCREW,ROUND HD. - #10-32N.F.X3/8
26	1	11011	COVER,HANDLE
27	1	FR44034	SCREW,FILLISTER HD. - #4-40N.C.X3/4

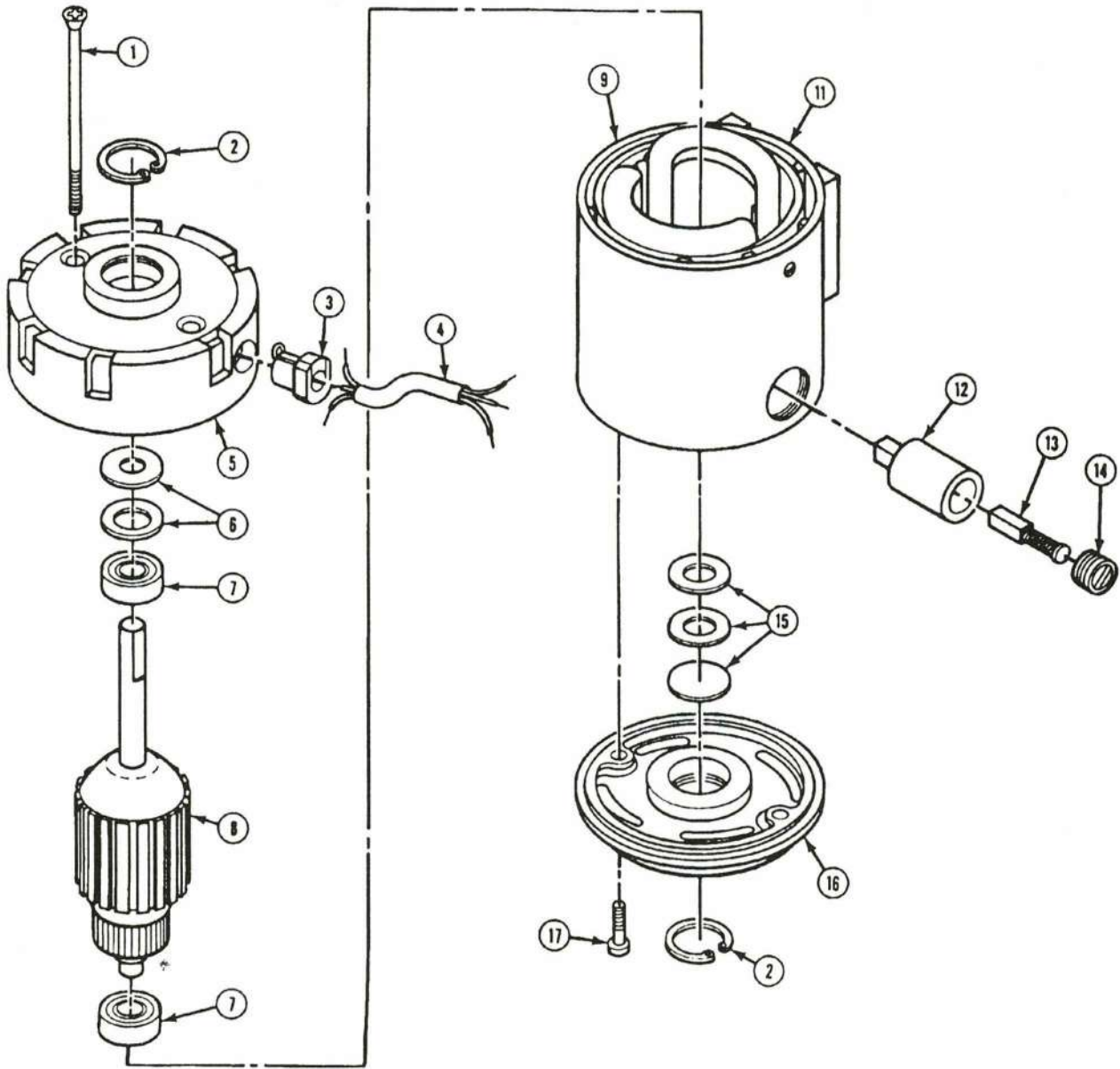

## MOTOR

**PART NO. 11997 115V - SINGLE PHASE - 1/12 H.P.**

**PART NO. 12451 220V - SINGLE PHASE - 1/12 H.P.**

**PART NO. 11898 115V - SINGLE PHASE - 1/6 H.P.**

**PART NO. 12899 220V - SINGLE PHASE - 1/6 H.P.**

ITEM	QUAN.	PART NO.	DESCRIPTION
1	2	12467	SCREW FLAT HD.PHILLIPS - #10-32N.F.X 3 1/4
2	2	12461	SNAP RING
3	1	12444	CORD GRIP-HEYCO
4	1	12470	CORD,MOTOR
5	1	12455	HOUSING,FRONT
6	1	12462	SPACERS,FRONT PRELOAD(SET)
7	2	11955	BEARING,BALL
8	1	12452	ARMATURE-115V-SINGLE PHASE-1/12 H.P.
		OR	
	1	12453	ARMATURE-220V-SINGLE PHASE-1/12 H.P.
9	1	12456	HOUSING,CENTER
10			
11	1	12472	ASSY.,FIELD-115V
		OR	
	1	12473	ASSY.,FIELD-220V
12	2	12458	HOLDER,BRUSH
13	2	12460	BRUSH
14	2	12459	SCREW,CAP-BRUSH HOLDER

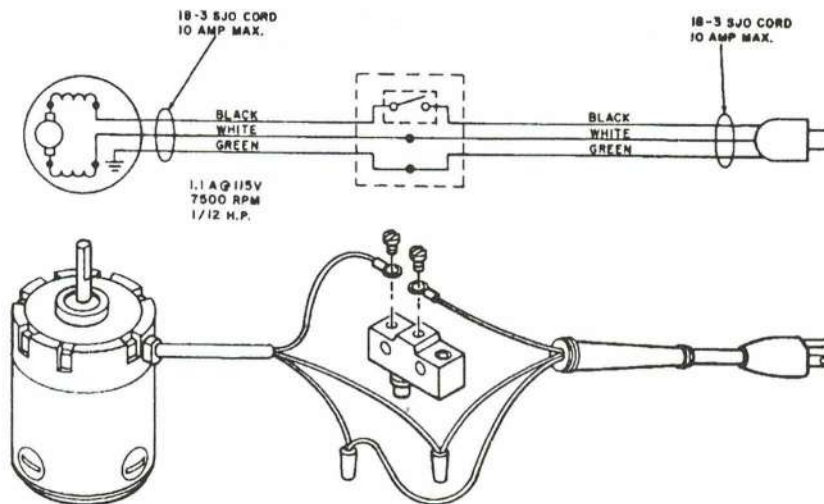

**THIS PAGE IS INTENTIONALLY LEFT BLANK.**

# OPTIONAL EQUIPMENT

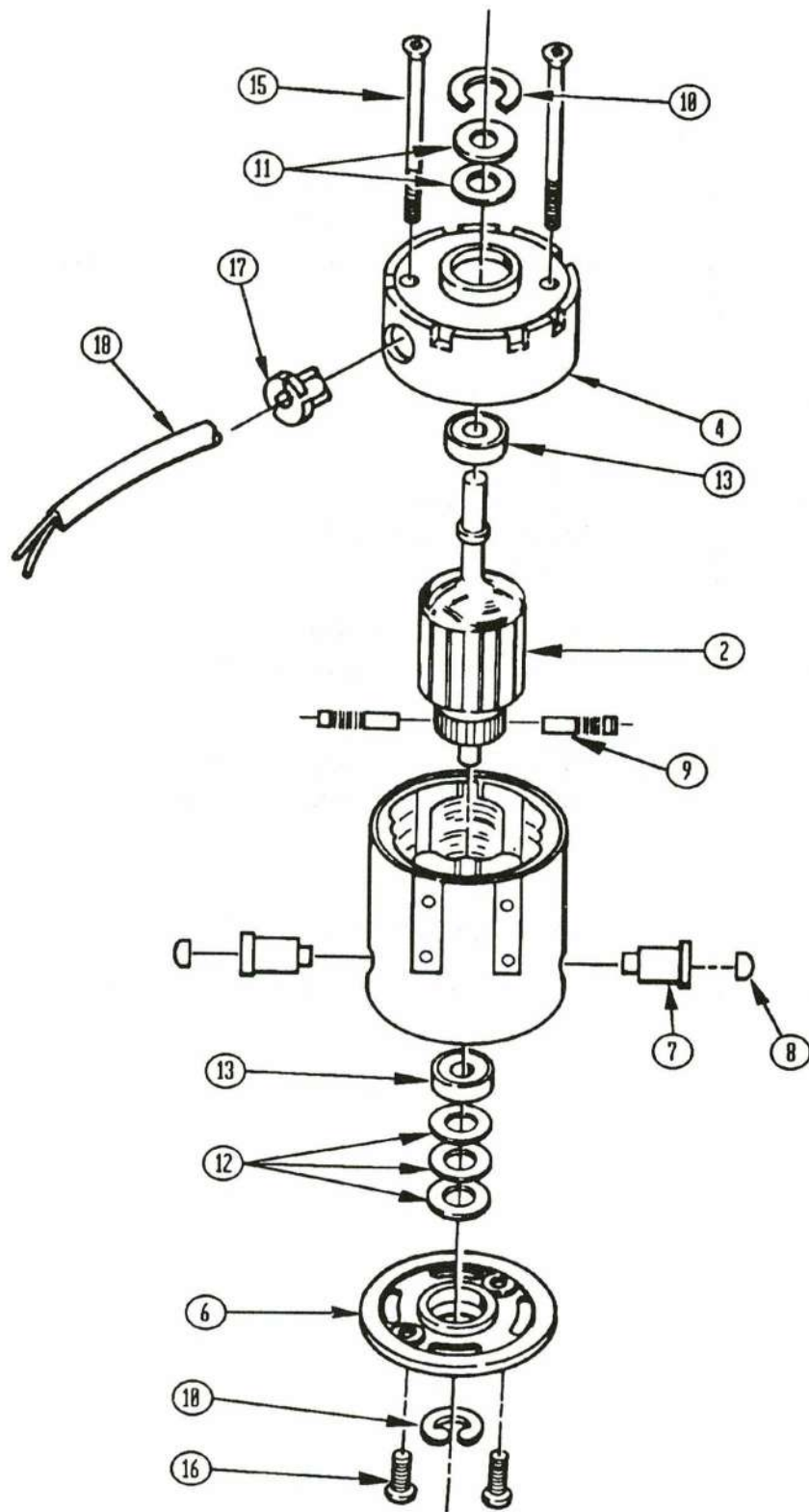

**MODEL ECR-12V  
12VDC MOTOR**

ITEM	QUAN.	PART NO.	DESCRIPTION
1			
2	1	REF	ARMATURE - 12 VDC - 1/12 H.P.
3			
4	1	12455	HOUSING,FRONT
5	1	REF	HOUSING,CENTER
6	1	12457	HOUSING,REAR
7	2	12478	HOLDER,BRUSH
8	2	12459	SCREW,CAP-BRUSH HOLDER
9	2	12479	BRUSH
10	2	12461	SNAP RING
11	1	12462	SPACERS,FRONT PRELOAD(SET)
12	1	12463	SPACERS,REAR PRELOAD(SET)
13	2	11955	BEARING,BALL
14			
15	2	REF	SCREW,FLAT HD.PHILLIPS - #10-32N.F.X 2 1/4
16	2	REF	SCREW,PAN HD.PHILLIPS - #10-32N.F.X1
17	1	12444	CORD GRIP
18	1	REF	CORD,MOTOR - 12VDC
19			
20	1	REF	ASSY.,FIELD-MAGNETIC - 12VDC
21			



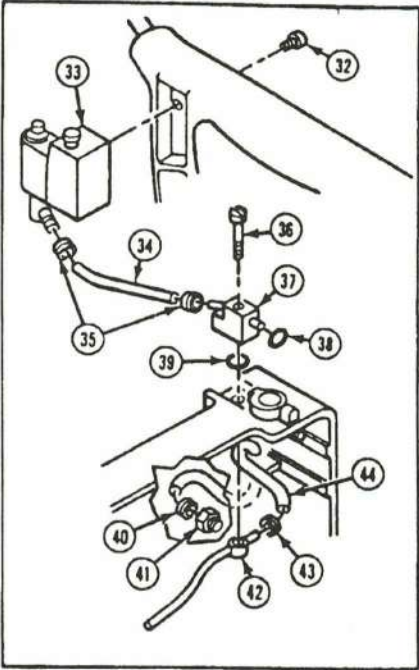
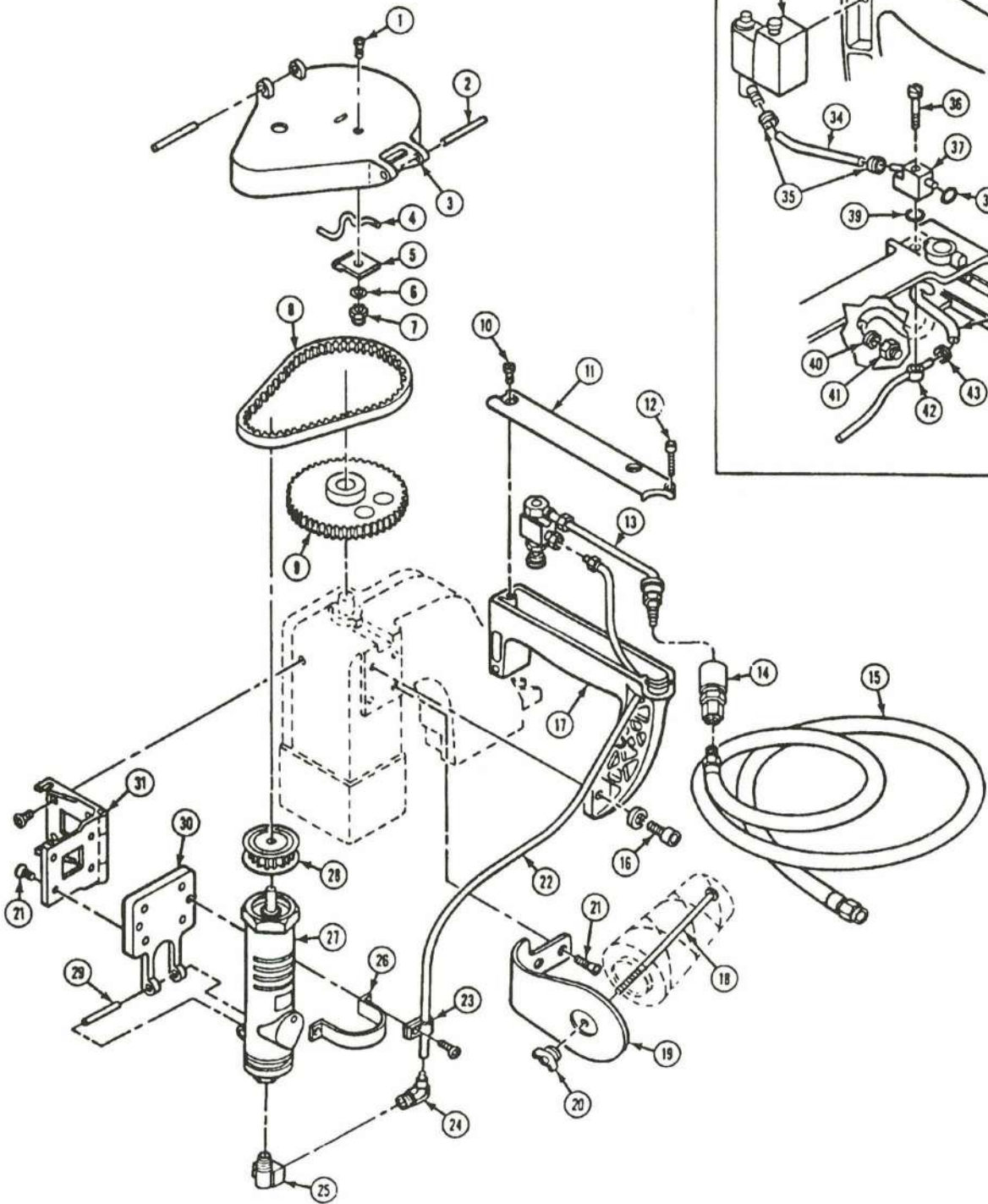

**MODEL ER (AIR)  
ASSEMBLY, HANDLE**

ITEM	QUAN.	PART NO.	DESCRIPTION
1	1	F832516	SCREW,FLAT HD.- #8-32N.C.X5/16"
2	2	PS14112	PIN,SPRING - 1/4 DIA.X 1 1/2
3	1	11018	GUARD,BELT - NFS USE 11198
4	1	11012	HANGER
5	1	11017	CLIP, HANGER
6	1	WIT8	WASHER,INTERNAL TOOTH - #8
7	1	NH832	NUT,HEX - #8-32N.C.
8	1	11340	BELT,TIMING
9	1	11339	PULLEY,TIMING - MAIN SHAFT
10	2	R103278	SCREW,ROUND HD. - #10-32N.F.X7/8"
11	1	11011	COVER,HANDLE
12	1	FR44034	SCREW,FILLISTER HD. #4-40N.C.X3/4"
13	1	11327	ASSY.,VALVE & MANIFOLD
14	1	11863	SOCKET,COUPLING
15	1	11864	AIR HOSE
16	1	SC142034	SCREW,SOC.CAP - 1/4-20N.C.X3/4"
17	1	11326	HANDLE,MODELER
18	1	11804	BOLT,THREAD CLAMPING
19	1	11815	STAND,THREAD
20	1	11805	NUT,WING - 1/4-20N.C.
21	10	SF103238	SCREW,SOC.FLAT - #10-32N.F.X3/8"
22	1.5'	P4969	TUBING,AIR SUPPLY-MOTOR
23	1	P4976	CLIP,NYLON
24	1	P4966	ELBOW,MALE - 1/4 PIPE X 3/8 TUBE
25	1	11346	ELBOW,90 - 1/4NPT MALE X 1/4NPT FEM.
26	1	11336	STRAP,MOTOR-AIR
27	1	11335	MOTOR,AIR
28	1	11338	PULLEY,TIMING-MOTOR
29	1	PS18138	PIN,SPRING - 1/8DIA.X 1 3/8"
30	1	11337	MOUNT,MOTOR-AIR
31	1	11906	ASSY.,HINGE-MOTOR MOUNT
32	1	B83212	SCREW,BINDING HD. - #8-32N.C.X1/2"
33	1	11450	ASSY.,PUMP-OIL
34	1	11141	TUBING,OIL PUMP
35	4	11472	SPRING,GARTER
36	1	B832114	SCREW,BINDING HD. #8-32N.C.X 1 1/4"
37	1	11475	MANIFOLD,OUTSIDE
38	1	11478	RING,"O"
39	1	11479	RING,"O"
35			SPRING,GARTER
41	1	11490	FITTING,BARBED
42	1	11485	WELDMENT,MANIFOLD-INSIDE
35			SPRING,GARTER
44	0.5	85128	TUBING,PLASTIC

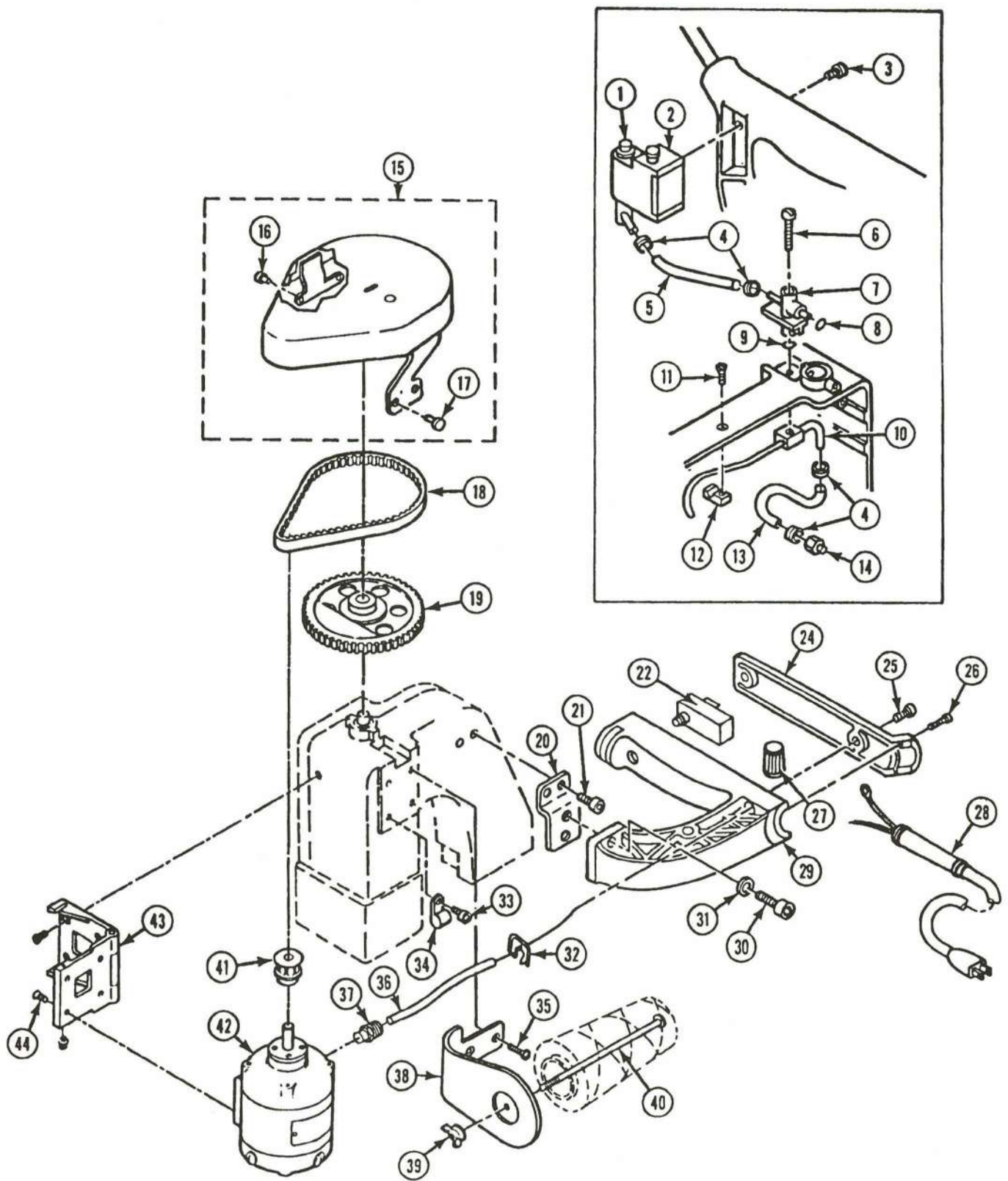

**MODEL EH  
ASSEMBLY, HANDLE & ELECTRIC DRIVE**

ITEM	QUAN.	PART NO.	DESCRIPTION
1	1	11450	ASSY.,PUMP OIL
2	1	11453	CAP,OIL RESERVE
3	1	B83212	SCREW,BINDING HD. - #8-32 X 1/2
4	4	11472	SPRING,GARTER
5	1	11494	TUBING,OIL PUMP(PLASTIC)
6	1	R832114	SCREW,ROUND HD. - #8-32 X 1-1/4
7	1	11475	MANIFOLD,OUTSIDE
8	1	11478	RING,"O"
9	1	11479	RING,"O"
10	1	11364	WELDMENT MAINFOLD-INSIDE
11	1	F64038	SCREW,FLAT HD. - #6-40 X 3/8
12	1	11359	CLIP,TUBING MANIFOLD
13	0.5 FT	85128	TUBING PLASTIC
14	1	11490	FITTING,BARBED
15	1	11239	ASSY.,BELT GUARD (MOD. EH)
16	2	B83214	SCREW,BINDING HD. - #8-32 X 1/4 (PART OF ITEM 15)
17	2	SB142038	SCREW,SOC.BUTTON HD. - 1/4-20 X 3/8 (PART OF ITEM 15)
18	1	11909	BELT
19	1	11904	PULLEY,MACHINE
20	1	11240	BRACKET,HANDLE
21	2	SB142038	SOC.BUTTON HD. - 1/4-20 X 3/8
22	1	11819	SWITCH
24	1	11011	COVER,HANDLE
25	2	R103238	SCREW,ROUND HD. - #10-32 X 3/8
26	1	FR44038	SCREW,FILLISTER HD. - #4-40 X 3/8
27	1	76000	WIRE NUT
28	1	11808	CORD,SET
29	1	11241	HANDLE,MODEL EH
30	2	SC142058	SCREW, SOC. CAP - 1/4-20 X 5/8
31	2	WF14	WASHER FLAT 1/4
32	1	11073	STRAIN RELIEF
33	1	B103238	SCREW,BINDING HD. - #10-32 X 3/8
34	1	11348	CLIP,NYLON
35	10	SF103238	SCREW,SOC.FLAT
36	1	REF	CORD GRIP
37	1	REF	CORD
38	1	11815	STAND,THREAD
39	1	11805	NUT,WING - 1/4-20
40	1	11804	BOLT,THREAD CLAMPING
41	1	11902	PULLEY,MOTOR
42	1	11990	MOTOR WITH CORD - 115V
		OR	
		11993	MOTOR WITH CORD - 220V
43	1	11906	ASSY.,HINGE-MOTOR MOUNT
44	2	11908	SCREW SEMS-PAN HD. - #6-32 X 7/16

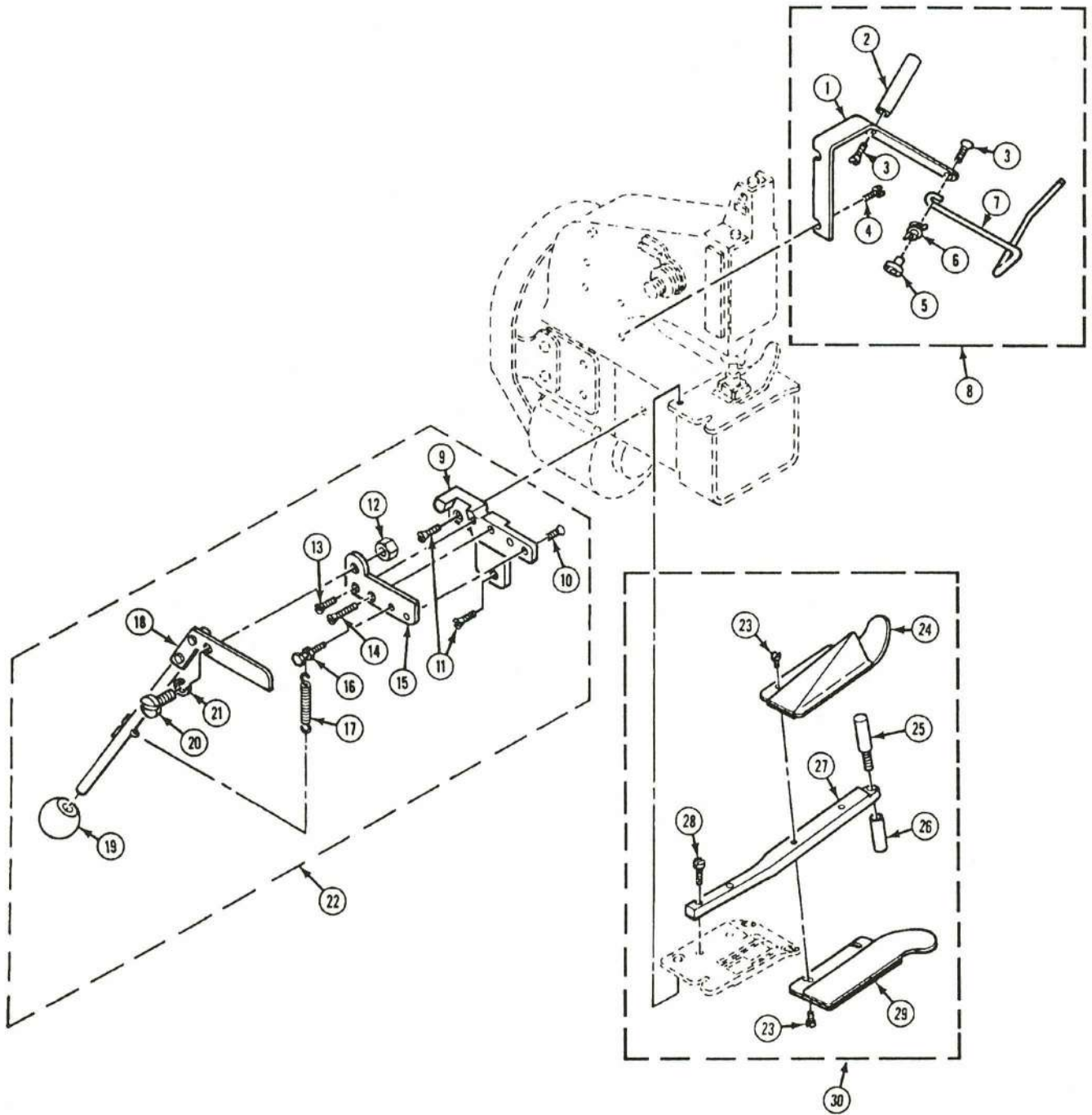

**MODEL ECR-1  
ASSEMBLY, TAPE ATTACHMENT**

ITEM	QUAN.	PART NO.	DESCRIPTION
1	1	A1608	BRACKET,HOLDER-REEL
2	1	A1609	SHAFT,HOLDER-REEL
3	2	F103212	SCREW,FLAT HD. - #10-32N.F.X1/2
4	2	B832516	SCREW,BDNG.HD. - #8-32N.C.X5/16
5	1	A1612	BUTTON
6	1	A1611	SPRING
7	1	A1610	FORM,WIRE
8	1	B1623	REEL,HOLDER(COMPLETE)
9	1	A1627	BRACKET,KNIFE MOUNT
10	1	F83214	SCREW,FLAT HD. - #8-32N.C.X1/4
11	2	SF103258	SCREW,SOC.FLAT - #8-32N.C.X5/8
12	1	NH1428	NUT,HEX - 1/4-28N.F.
13	1	F83212	SCREW,FLAT HD. - #8-32N.C.X1/2
14	1	SF83278	SCREW,SOC.FLAT - #8-32N.C.X7/8
15	1	A1602	BLADE,STATIONARY
16	1	A1603	STUD,SPRING HOLDER
17	1	A1607	SPRING
18	1	B1626	ASSY.,BLADE & HANDLE
	1	A1604	BLADE,MOVING
	1	P1619	PIN,COTTER-3/32DIA.X1/2LG.
	1	A1605	HANDLE
	2	P1618	RIVET
19	1	P1606	KNOB,PLASTIC
20	1	B142858	SCREW,BDNG. HD. - 1/4-28N.F.X5/8
21	1	WL14H	WASHER,LOCK-1/4 HEAVY
22	1	B1633	KNIFE ASSY.,COMPLETE(MODEL E)
23	4	B832316	SCREW,BINDING HD. - #8-32N.C.X3/16
24	1	A1616	FOLDER,FRONT
25	1	A1614	GUIDE,TEE-MLE
26	1	A1615	GUIDE,TEE-FEMALE
27	1	B1613	SUPPORT,BACK-FOLDER
28	2	B832716	SCREW,BDNG. HD - #8-32N.C.X7/16
29	1	A1617	FOLDER,REAR
30	1	B1624	FOLDER,COMPLETE

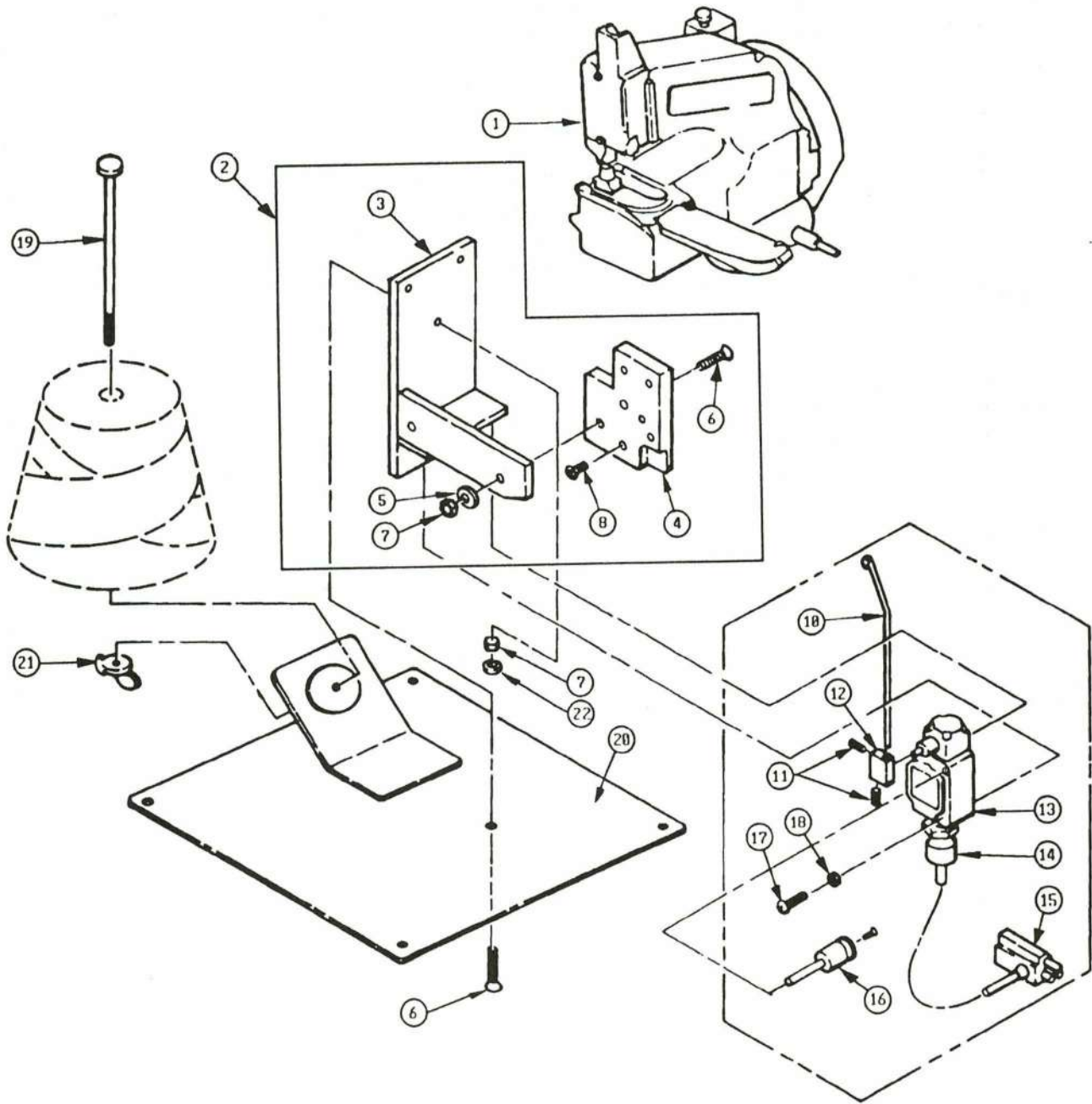

## ASSY., HORIZONTAL STITCHER

ITEM	QUAN.	PART NO.	DESCRIPTION
1	1	11695	ASSY.,MOD EH HORIZONTAL STITCHER (HEAD)
2	1	A2455	ASSY.,BRACKET
3	1	A2457	WELDMENT,BRACKET MOUNTING
4	1	A2458	BRACKET-MOUNTING
5	2	WS14	WASHER
6	4	SF14201	SCREW SOC.FLAT 14-20X1"
7	4	NH1428	NUT,HEX-1/4-28N.C.
8	2	SF103212	SCREW,SOC.FLAT - #10-32N.F.X1/2"
9	1	A2586	ASSY.,ACTUATOR SWITCH
10	1	A1845	FEELER,SWITCH
11	2	SS103238	SCREW,SOC.SET - #10-32N.C.X3/8"
12	1	A4368	BLOCK,LEVER-MICROSWITCH
13	1	P2587	SWITCH,ACTUATOR
14	1	P3478	CORD GRIP
15	1	1080	CORD SET
16	1	A2589	ASSY.,SAFETY PIN
	1	R83234	SCREW,ROUND HD. - #8-32N.C.X3/4
17	2	SC1032112	SCREW,SOC.CAP - #10-32N.F.X 1 1/2
18	2	WL18	WASHER,LOCK - #10
19	1	1841	ROD,THREAD-CLAMPING
20	1	A2568	WELDMENT,BASE MOUNTING(HORIZONTAL STITCHER)
21	1	11805	NUT,WING - 1/4-20N.C.
22	2	WL14	WASHER,LOCK-1/4"